



# Newsletter

27<sup>th</sup> March 2026



Hannah Crotty  
Headteacher

What a wonderful way to finish our Spring Term! The children have shown tremendous effort in their learning and have thoroughly enjoyed all the activities we have taken part in together.

Our Easter Bonnet Parade this week was a real highlight. The children's creative designs were absolutely delightful, and their singing brought a smile to everyone. It was fantastic to see so many parents and carers joining us, your continued support means so much to us. We wish all our families a restful and enjoyable break and a very Happy Easter.

We look forward to welcoming the children back to school on **Monday 13<sup>th</sup> April**.

## Easter Bonnet Winners:

Nursery – Poppy  
Reception – Dominic  
Year 1 – Aisha  
Year 2 – Bea  
Year 3 – Tiarla -Nae  
Year 4 – Adam  
Year 5 – Isla  
Year 6 Dyna  
Overall EYFS Winner – Sumaya  
Overall KS1 Winner – Paula  
Overall KS2 Winner - Sienna



## Teaching and learning

### Nursery

This half term we have loved learning about how windmills work through the story The Little Red Hen. We learnt about what happens to corn when it goes to the windmill and how the flour is made. We enjoyed exploring how corn is ground down and crushed by using large rocks to crush rice crispies! We also made our own bread just like Little Red Hen.



## Teaching and learning

### Reception

This half term in Reception, we have focused on innovations and inventions, encouraging the children to use their imagination to design and create their own ideas. We also explored inventors from the past, using them as inspiration for our own thinking and creativity. Alongside this, we learned about a range of celebrations, including Holi, Mother's Day, Eid and Easter. The children took part in lots of fun and creative activities to help them understand and share what they had learned about these special occasions.

Our class story for this half term was *Someone Swallowed Stanley*, which helped the children understand the importance of looking after our world. They learnt about recycling, the impact of plastic pollution and how it can harm animals and the environment.

As part of British Science Week, we carried out an exciting experiment linked to our learning about materials. Our enquiry question was: *Can we make dirty water clean?* The children worked together to create their own water filters and were fascinated by the results.

We also put on a fantastic class assembly, where the children showed great courage and confidence speaking in front of parents and the whole school. We are incredibly proud of all they have achieved this half term!



## Teaching and learning

### Year 1

'With British Science Week in March, Year 1 have been learning about the properties of different materials. In preparation for our Science Fair stall, we compared materials, including if they were waterproof or not, strong or weak and rough or smooth. We saw why materials are used for certain purposes and learnt about what makes materials versatile and useful for everyday objects and purposes.'



## Teaching and learning Year 2

This half term Year 2 have been busy exploring The Storm Whale in English lessons. We have written our own imaginative narratives focusing on adding detail to our writing. We also wrote clear and detailed instructions on how to take care of a whale thinking carefully about appropriate adverbs and conjunctions. In maths, we have been developing our understanding of length and height by measuring and comparing objects using standard units.

We have also been learning about fractions including recognising and finding halves and quarters of shapes and quantities. In Spanish we explored the seasons and learnt to name and describe them. In history we discovered the important journey of women gaining the right to vote, learning about fairness and how society has changed over time. We discussed why this was such an important step towards equality. We also embraced British Science Week by learning about sustainability, exploring how we can look after our planet through small changes in our everyday lives. It has been a fantastic half term full of curiosity, creativity and enthusiasm for learning!



## Teaching and learning Year 3

In Year 3, we have been learning about climate change. First, we learnt the difference between weather and climate. Then we learnt about the different climate zones across the world. We learnt about the Industrial Revolution and, in particular, how this impacted Nottingham. We created timelines of how Lenton has changed over time. We learnt about greenhouse gases and how they lead to the greenhouse effect. We are now learning how we can help to slow climate change and we are writing to persuade others to do this too.



## Teaching and learning

### Year 4

Year 4 have been very busy this half term. After visiting Primary Art, some of the children planted seeds in their compostable pots that they made. Some children planted poppies, as we have discussed these in our learning of World War 1, linked to our English text, FaRther. Other children planted sunflowers.

Audrey has been sending updates of her growing seeds on Showbie.



Audrey's growing seeds

In addition to this, Science has been very exciting this half term - full of experiments. We have been learning about the states of matter: gases, liquids and solids. We have explored these states and explored how materials can change state through cooling and heating. We even discovered that some materials are difficult to identify. We were able to explore oobleck. At times when we touched it, it felt hard like a solid and at other times it was gooey like a liquid. Another experiment we engaged in was heating up solids to see them change into liquid. We had to predict and investigate which material melted the quickest.



## Teaching and learning

### Year 5

In Science this term, Year 5 have been learning about Space and in preparation for the Science fair, they have been combining their science knowledge and DT skills to design and make some incredible Lunar Buggies. They were tasked with creating a buggy that could carry two astronauts, to be able to move in a sandy, rocky environment, send video recordings back to Earth and to communicate with ground control back on Earth. They researched previous inventions and used some of the ideas to innovate and improve in order to create their own. They used Tinker cad to bring their ideas to life and create a working model to use at the science fair.

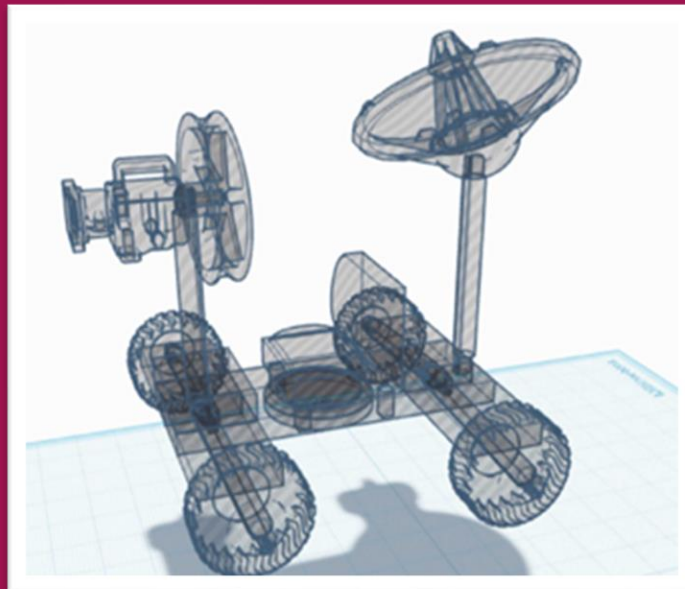
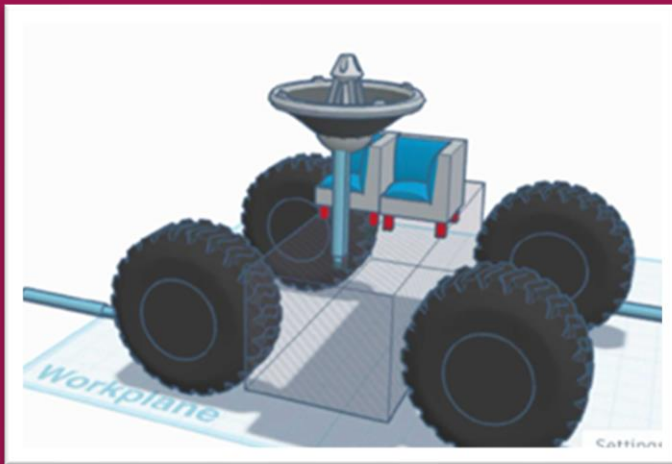

## Teaching and learning

### Year 6

Year 6 worked collaboratively in groups to carry out an experiment applying their knowledge of electrical circuits to design and create their own torches. Through this hands-on activity, they developed their teamwork, problem-solving, and practical science skills while exploring how different components work together to complete a functioning circuit.

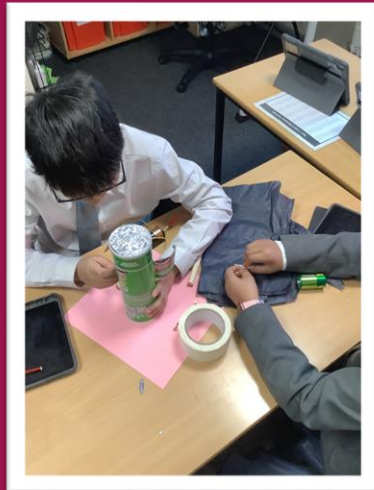

## Year 3 Contemporary Visit

We visited the Contemporary Art Gallery to see the exhibition "Lines that World a River" by Shahani Rajani. The children learnt about how dams and climate change are affecting the rivers in Pakistan, and how the communities are using art to remember them. It was lovely to see children, and staff, with Pakistani heritage in particular really connecting with the images and language. The children also took part in activities such as building something that reminds them of a particular memory and seeing how light moves along a reflective boat structure.

After our time at the gallery, we visited a real river - the River Trent - to watch how the water moves and think about how we want to represent that in our own art work back at school. The swans and seagulls seemed very pleased to see us!

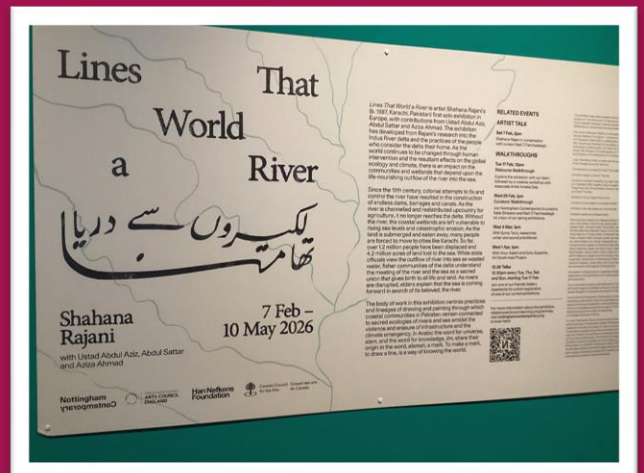
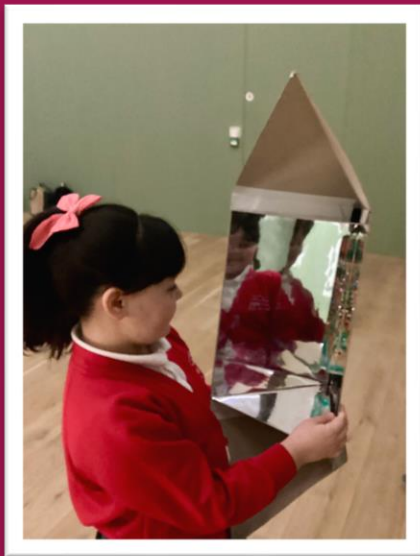

## Cinema Trips

Children from Year 1 to Year 6 were treated to a truly special experience when they had the opportunity to visit the cinema. The children were wonderfully behaved and represented our school brilliantly, making the experience enjoyable for everyone involved. For some of our younger pupils, it was their very first time visiting a cinema, which made the day even more memorable. A very special thank you to Miss Davies, who made this exciting opportunity possible.



## International Women's Day Mother's Day

It was a delight to see so many parents attend our Mother's Day afternoon tea and celebration of International Women's Day on Friday 13<sup>th</sup> March. The children were very passionate about sharing the learning they had undertaken during the day and celebrating the achievements of women.



## Science Fair

Thank you so much to everyone who attended our science fair on Thursday. There was such a great buzz around the hall as the children explored all the different stalls. The children explained their scientific thinking around reflection, electricity, bacteria and more to their peers and it was great to see parents getting involved too. As Hawry in Year 6 says, it was "amazing experiencing all the different things".



## Eid Mubarak

This week, the children have been learning about the Muslim celebration of Eid. They explored how Muslim families prepare for Eid and discovered the many different ways the festival is celebrated both in the UK and around the world. The children also learnt about the importance of gratitude and charity during this special time.

It was lovely to hear the children share their own family celebrations and experiences. Across the school, everyone enjoyed a delicious Eid meal, thoughtfully prepared by our wonderful kitchen team.

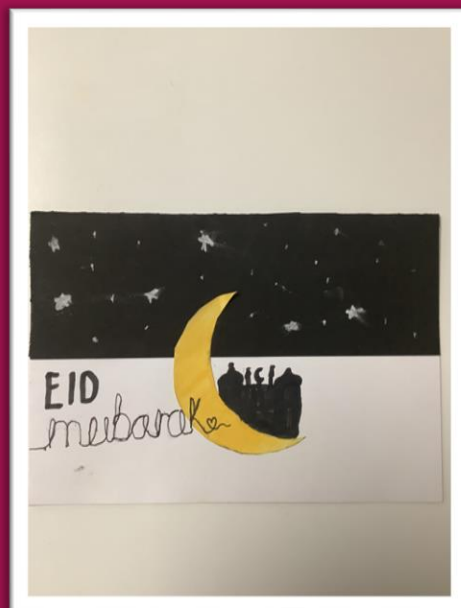
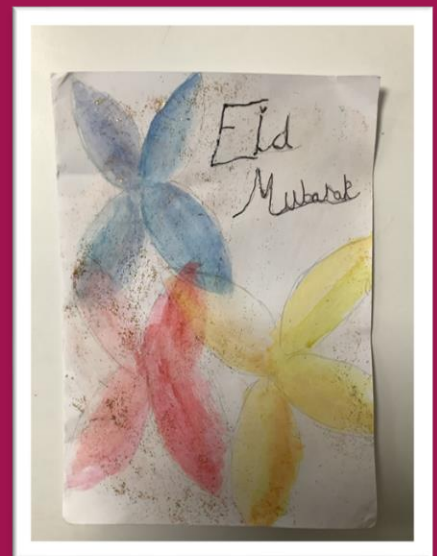
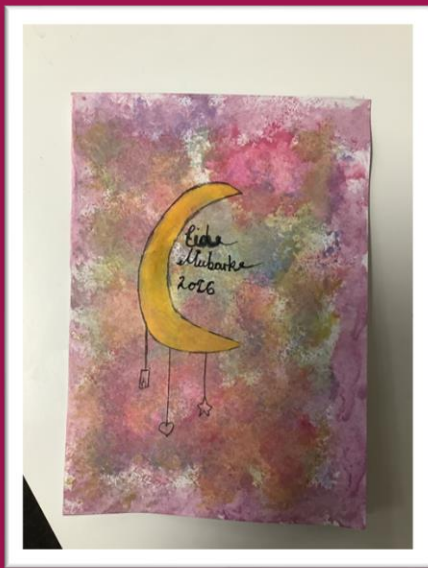

## Spanish in Year 2

Year 2 were excited to welcome Matilda from the university, who visited to read the story Boas Bad Birthday. The children thoroughly enjoyed listening to the story and took part in discussions about the different emotions the characters experienced. They also talked about the kinds of food we might have at birthday parties sharing their own ideas and experiences. Year 2 were highly engaged throughout the session and impressed Matilda by confidently showing that they already knew how to sing happy birthday in Spanish!

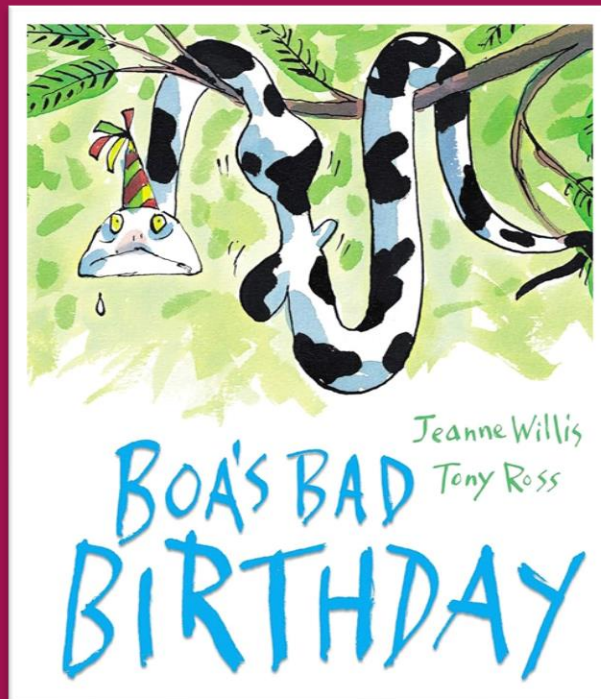

## Comic Relief

We had a brilliant time celebrating Comic Relief on Friday 20<sup>th</sup> March! The children arrived in school full of smiles, proudly wearing their outfits that make them smile and sharing lots of laughter throughout the day. It was wonderful to see everyone getting involved to support such an important charity.

A huge **thank you** to all our families for your generous donations. Your support helps to make a real difference to those in need.



## Goodbyes and Welcomes

Miss Hampshire, who has been a valued member of our team, will be leaving Edna G. Olds Academy at the end of the spring term to undertake new challenges. We are grateful for her dedication during the time she has worked at Edna G. Olds Academy and wish her all the best with her future career plans.

Whilst it is always difficult to say goodbye, we are pleased to announce that Mrs Lefevre will be joining our team as the new Year 2 teacher. Mrs Lefevre is an experienced teacher and will continue to provide an enriching and supportive learning environment for your children.



## Attendance

During this week you will have received an attendance letter. These letters are nothing to worry about, they are simply a helpful way to show you how your child's attendance is looking so far this academic year. Our aim is to keep everyone informed and working together to support good attendance and positive learning habits. If you have any questions after receiving your letter, please just get in touch.

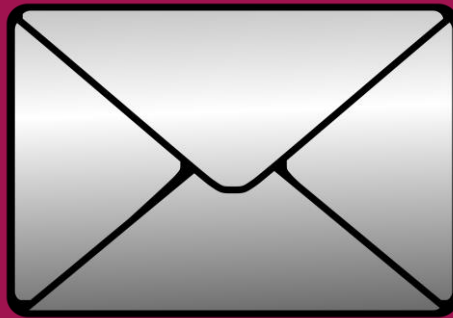

## Half Term Information



### Easter holiday activities for families



Looking for things to do this Easter? There are plenty of activities taking place across Nottingham to keep children and families entertained over the school holidays. From fun days out and creative workshops to sports sessions and community events, there's something for all ages to enjoy.

[Holidays Activities | Ask Lion - Nottingham City Directory](#)

## Pupil News

Talia and Marlo Year 2 have taken part in a swimming competition. They said It was so exciting to be able to participate as we had been training hard.

They both won medals and are feeling very proud of themselves.

Well done girls!



Kiana, Year 2, has received a bronze medal in gymnastics. Kiana said it was especially exciting because it was the first medal that she had won.

Kiana trains weekly and it has helped her to become resilient.

Well done Kiana!





# Core Values Achievers



Nursery	Cassius	For always being a good friend and demonstrating empathy towards others.
	Nainika	For developing her confidence and social skills and building good relationships with her peers.
Rec	Dominic	For demonstrating fantastic enthusiasm in our science experiment.
	Sage	For always demonstrating all of our core values, being polite and being a kind friend.
Year 1	Ali	For his brilliant focus in phonics and making excellent progress.
	Aisha	For demonstrating fantastic effort and care in her writing.
Year 2	Year 2	For being a pleasure to teach and following our core values every day.
Year 3	Zaid	For being an excellent role model and always following our core values.
	Ella	For her growing confidence and using her voice in class.
Year 4	Robbie	For always being motivated in all lessons and showing great resilience.
	Lawren	For always being respectful and having a positive attitude towards learning.
Year 5	Sienna	For always demonstrating all of our core values and being an excellent role model.
	Mazin	For always demonstrating all of our core values and being an excellent role model.
Year 6	Myah	For her resilience and effort to improve her mathematics.
	Morris	For being an excellent role model in Year 6.

Thank you for your continued support.

Mrs Hannah Crotty  
Headteacher